

# Ikegami

**HD**  
High Definition

Preliminary

*Full Digital Small and Compact 3 CMOS HDTV Camera*

# HDL-23



The HDL-23 is a Full Digital and Full Resolution HDTV camera equipped with three high performance progressive CMOS sensors, providing superb color reproduction. The optical block camera head is designed for minimum size and weight allowing use in a wide range of POV applications.

The CCU is DC powered for field use, and the camera system can be controlled by Ikegami's traditional broadcast remote control panels. Small size, light weight, easy operation and handling make the HDL-23 well suited for applications requiring an ultra-compact HDTV camera.

# Full Digital Small and Compact 3 CMOS HDTV Camera HDL-23



## High Performance Progressive CMOS Sensors

1920 x1080 progressive CMOS sensors are employed to achieve 1000TVL horizontal resolution, F10 sensitivity and 54dB SNR.

## Compact and Light Camera Head

The compact and light camera head permits use in various application with easy operation and handling.

## Various Output Signals

Not only two HD-SDI outputs, but also other output signals such as DVI, HDMI(Optional) are available. And it supports simultaneous outputs for SD VBS and Y/C.

## Auto Video Level Control

By synchronized control of Auto Gain and Auto Knee, video maintains the correct level automatically even though lighting conditions change. This feature is beneficial when using compact manual iris C-mount lenses, allowing the iris to be fixed at the best setting for depth-of-focus and sensitivity. The starting gain for AVC can be set at 3dB increments, producing maximum SNR for the each application.

## Column Adding

Column adding achieves two times standard sensitivity by using 2 horizontal columns for each pixel. Also, line mix achieves another two times standard sensitivity by using 2 vertical rows. In total four times standard sensitivity can be achieved for applications where high sensitivity is required with some sacrifice in resolution.

## ICCP Command Control

The camera supports Ikegami's traditional broadcast control command protocol (ICCP), so our broadcast remote control panels used with other EFP cameras can also be used on this POV camera as a part of the overall broadcast camera control system.

## 3D Application Ready

An image flip function supports 3D video production when using 3D rigs. The OCP-200 in network configuration can support 3D with parallel operation of two cameras (option).

## System application

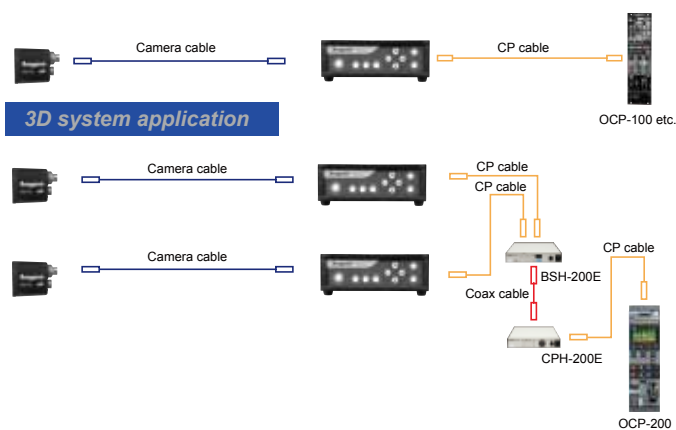

## ■ Ratings

Scanning System	CMOS Sensor Output: Progressive 1920 x 1080 59.94Hz / 50Hz Aspect Ratio:16:9
Image Sensor	Three 1/3-inch CMOS sensors
Optical System	RGB Prism
Lens Mount	C-Mount
Power requirement	+12V DC ±10%
Power consumption	Approx. 20W
Control Signal Input	Ikegami Protocol
Ambient Temperature	0 ~ +40°C
Input Signals	External Tri-level Sync: 0.6Vp-p / 75 ohm x1ch * The color frame from down converted output can not be locked.
Output Signals (HDTV)	
HD-SDI	1080i/59.94Hz, 50Hz 0.8Vp-p / 75ohm x2ch
DVI	1920x1080p/59.94Hz, 50Hz x 1ch
HDMI (Option)	1920x1080p/59.94Hz, 50Hz x 1ch
Moving/Still Picture	Still Picture Output: JPEG 1920 x1080
File (Option)	Transmitting Moving Picture: H.264 (6~12 Mbps)
SDTV (down converted)	
SD-VBS	1.0Vp-p / 75 ohm x1ch
SD-Y/C	Y : VS1.0Vp-p / 75 ohm x1ch C : 0.286Vp-p / 75 ohm
Cable Length	5m *Can be extended to 15m with 10m extension cable. Head: W34 x H40 x D40 mm approx. (W1.38 x H1.63 x D1.63 inches)
Dimensions	CCU: W170 x H58 x D200 mm approx. (W6.75 x H2.25 x D7.88 inches)
Weight	Head: Less than 0.1kg (0.22 lbs) CCU: Less than 3kg (6.61 lbs)
■ Performance	
Sensitivity	F10 at 2000lx, 3200K
S/N	54dB
Limiting Resolution	1000TVL
Registration Error	0.05% or less
Shutter Speed	1/60 ~ 1/2000 (59.94Hz)
(Rolling Shutter)	1/50 ~ 1/2000 (50Hz)



Design and specifications are subject to change without notice.

## Ikegami Tsushinki Co.,Ltd.

■ URL : <http://www.ikegami.co.jp/en/>

U258B135-SELF

■ Head Office : 5-6-16 Ikegami, Ohta-ku, Tokyo 146-8567, Japan ..... TEL.03-5700-1111 / FAX.03-5700-1137  
 ■ Overseas Sales Division : 5-6-16 Ikegami, Ohta-ku, Tokyo 146-8567, Japan ..... TEL.03-5700-4117 / FAX.03-5748-2200  
 ■ Beijing Office : No.417 Jia Tai International Mansion, No. 41 East Fourth Ring Road, Chaoyang District, Beijing, China ..... TEL.010-85711804 / FAX.010-85711804

## Ikegami Electronics (U.S.A.), INC.

■ URL : <http://www.ikegami.com>

■ Headquarters : 37 BROOK AVENUE, MAYWOOD, NJ 07607 ..... TEL.(201) 368-9171 / FAX.(201) 569-1626

## Ikegami Electronics (Europe) GmbH

■ URL : <http://de.ikegami.co.jp>

■ Headquarters : Ikegami Strasse 1, D-41460 Neuss, Germany ..... TEL.02131-1230 / FAX.02131-102820  
 ■ U.K. Branch : Unit E1 Cologne Court, Brooklands Close, Windmill Road, Sunbury-on-Thames, Middlesex TW16 7EB, England ..... TEL.01932-769700 / FAX.01932-769710